

General Information:

The many benefits of variable speed drives (VSD) in electric-submersible pumping systems (ESP) have led to exponential growth in the use of these devices in production fields handling high fluid output levels. The use of VSDs causes some difficulties when connected to the electrical power system, due to the fact that static power converters produce non-linear loads, affecting the natural sine shape of alternating current, introducing harmonic currents into the electric power network that could cause interference in the communication circuits and damage the equipment installed on the network.

Specially designed transformers called phase shift transformers can help to mitigate the effect of speed drives when connected to the network, by helping to reduce the harmonics reaching the electrical network, depending on the number of pulses of the VSD. This harmonic distortion may be mitigated by increasing the number of rectifying sections used in the VSD; for instance, a 12 pulse converter has 2 rectifiers sections that are 30° out of phase, an 18 pulse converter has 3 rectifiers with a phase shift of 20° and a 24 pulse converter has 4 rectifiers that are 15° out of phase. Therefore, the larger the number of pulses, the smaller the trigger distance between waves, resulting in a shorter distance between wave crests and thus in lower harmonic distortion.

It is important to take into account that, the higher the number of pulses, the more complex the system becomes and therefore the cost of the required equipment will be considerably higher.



Scope of the offer

Manufactured in accordance with applicable ANSI, IEC and NTC standards and/or specific customer specifications.

Voltages

Three-phase: 260 kVA to 1500 kVA.

Connection type:

Delta - ZigZag

Product Description

The Magnetron 24-pulse PST has been specifically designed for the connection of variable speed drives used in ESP to the electric power distribution grid, based on Magnetron's extensive knowledge of transformer design and manufacture and on the technological developments of the main manufacturers of variable speed drives, resulting in a device that is a perfect fit to meet the technical and economic needs of the oil industry.

The 24-pulse step-down phase-shift transformer has a primary winding designed for connection to power sources with voltages of 34.5kV, 13.8kV, 13.2kV, 4.1kV, 0.48kV. (Bear in mind that the transformer is designed only for one type of power source voltage.) Not switchable from 13.8kV to 13.2kV or any of the other options. There are four secondary windings, each at 480V, 15° out of phase with each other, for connection to 24-pulse variable speed drives.

24 Pulses Phase Shift Transformer



Special cases:

- Transformers with different primary or secondary winding voltages from those indicated here can be manufactured upon review of the requirements by our engineering group.

Transformers typically consist of an active part made up of the core (magnetic circuit), the coil (electric circuit) and the yoke clamp, determined in accordance with the type of transformer, and placed in a tank that provides the equipment with specific features, depending on its intended application.

Coils:

Concentric circular or rectangular sections with copper or aluminum windings.

Insulation: High-quality paper coated with epoxy resin.

Cores:

Shell Type or Core Type, wound or stacked, set up in groups for easy assembly and disassembly without loss of dimensional characteristics, guaranteeing low losses and excitation currents.

Materials: Cold-rolled grain-oriented silicon electrical steel sheet with insulating coating on both sides, low core loss and high permeability.

Yoke clamps:

Made of cold-rolled and hot-rolled steel, they clamp the core, with individual bolted caps enabling easy disassembly for maintenance purposes.

Ensure high resistance to short circuit mechanical stresses, low noise levels and low excitation currents.

Tanks:

Rectangular in shape, made of cold rolled or hot rolled steel plates with reinforcements capable of withstanding internal pressures due to temperature rise and mechanical stresses due to equipment installation and handling. Three-phase TANKS include a cabinet that is studded or welded to the transformer and serves as protection for the Low Voltage and Medium Voltage circuits, with a mechanical locking system which, for safety reasons, prevents opening of the compartments without the appropriate key.

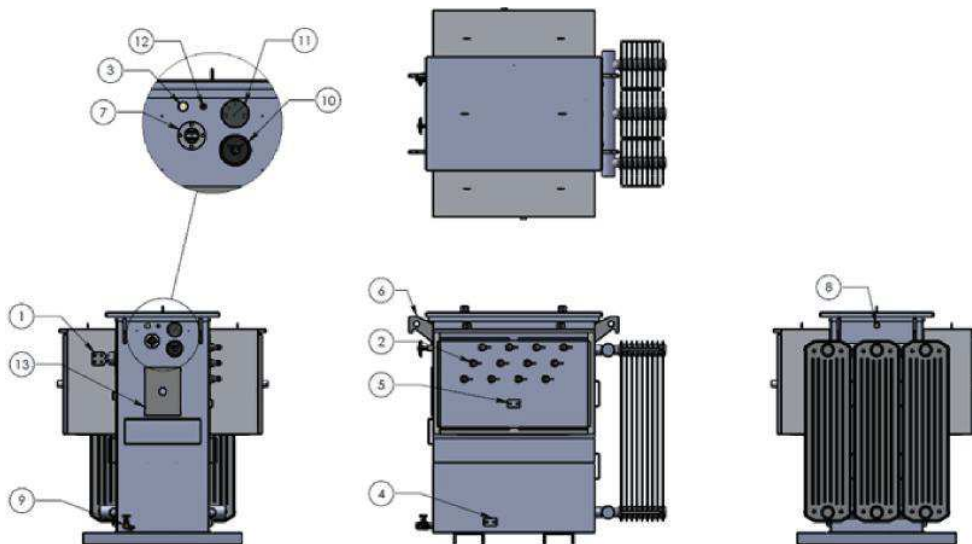

ITEM	DESCRIPTION	QUA
1	Primary insulator	3
2	Secondary insulator	12
3	Pressure relief valve	1
4	Tank grounding	2
5	PV/SV grounding	2
6	Lifting lugs	4
7	Oil level	1
8	Fill plug	1
9	Drain valve	1
10	Oil Thermometer	1
11	Vacuum Pressure Gauge	1
12	Nitrogen filling	1
13	Nameplate	1